



Trinity FTV Combi (110, 150 and 190MBH) High Efficiency Gas-Fired Condensing Boiler

SUBMITTAL SHEET
Section 1 – General Specifications
Section 2 – Product Dimensions
Section 3 – Field Wiring

Project Name: _____ Date: _____
Location: _____
Engineer: _____
Contractor: _____ Rep: _____

1 – GENERAL SPECIFICATIONS

Product Features:

- ✓ Certified to ANSI Z21.13 / CSA 4.9 Gas-fired Boiler Standard
- ✓ SA240-439 Stainless Steel Heat Exchanger
- ✓ Vertical Firetube Boiler
- ✓ ASME "H" stamped boiler, designed and constructed in compliance with the ASME Boiler and Pressure Vessel Code Section IV
- ✓ Maximum operating pressure 50 psi
- ✓ Modulating burner, 10:1 turndown ratio
- ✓ Direct Spark Ignition
- ✓ Instantaneous domestic hot water
- ✓ 120 VAC convenience outlet for condensate pump
- ✓ Wall (standard) or floor mounting (w/ opt. kit, NTI part # 84630)
- ✓ Zero clearance to combustibles (clearances required for service)
- ✓ Field conversion from Natural Gas (factory) to Propane
- ✓ Certified as Direct Vent (sealed combustion) or for use with indoor combustion air
- ✓ Optional Sidewall vent kits
- ✓ Built-in pressure bypass
- ✓ On / Off switch
- ✓ Water Pressure Sensor
- ✓ Integrated DHW heat exchanger
- ✓ Integrated DHW temperature/flow sensor
- ✓ Integrated Grundfos 15-78 boiler circulator
- ✓ Integrated diverter valve

Control Features:

- ✓ Integral microprocessor safety control
- ✓ Domestic Hot Water Priority timer
- ✓ Domestic Hot Water pre-heat option
- ✓ Outdoor Reset
- ✓ Warm weather shut down
- ✓ Freeze protection
- ✓ Cascade up to 16 FTV series boilers
- ✓ Outdoor reset temperature boost
- ✓ Adjustable pump post purge
- ✓ Run time accumulation
- ✓ Night setback option
- ✓ Lockout and error history

Factory Supplied Items:

- ✓ 10K thermistor outdoor sensor
- ✓ 30PSI [206.8 kPa] ASME Relief Valve
- ✓ Pressure / Temperature Gauge
- ✓ Condensate Trap
- ✓ Low-Loss header w/ 1" sweat connections
- ✓ DHW Y-strainer Filter

Model	Water Connection NPT	DHW Connection NPT	Gas Connection NPT	Vent/Air-Inlet Pipe Diameter	Vent/ Air-Inlet Max. Length		Approx. Wt. w/ Water
					2" pipe	3" pipe	
FTV110C	¾" (Male)	¾" (Male)	½" (Female)	2" or 3"	100 ft	150 ft	88 lb
FTV150C				2" or 3"	100 ft	150 ft	98 lb
FTV190C				3"	n/a	150 ft	120 lb

Performance Specifications

Model	Input Modulation, MBH	DOE Heating Capacity, MBH	NET I=B=R Rating, MBH	AFUE %	DHW Flow Rate at 77°F rise, gpm
FTV110C	11 - 110	101	88	95	2.7
FTV150C	15 - 150	138	120	95	3.6
FTV190C	19 - 190	176	153	95	4.5



NTI Boilers Inc.

NTI Boilers Inc. 30 Stonegate Drive, Saint John, NB E2H 0A4 Canada

Technical Services: 1-800-688-2575 Fax: 1-506-432-1135 Web: [http:// www.ntiboilers.com](http://www.ntiboilers.com)

NTI Boilers Inc. reserves the right to change these specifications without notice



Trinity FTV Combi (110, 150 and 190MBH) High Efficiency Gas-Fired Condensing Boiler

SUBMITTAL SHEET
Section 1 – General Specifications
Section 2 – Product Dimensions
Section 3 – Field Wiring

2 – PRODUCT DIMENSIONS - in.

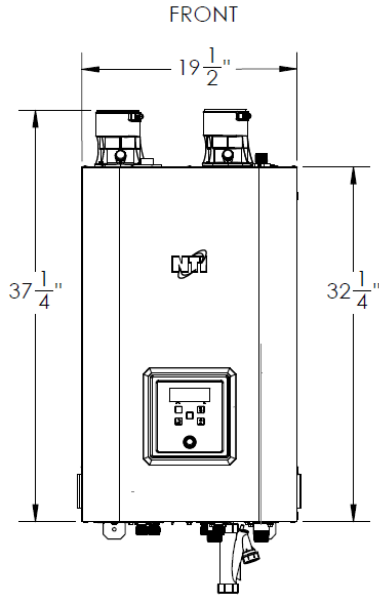

TOP

	DIM	FTV110	FTV150	FTV190
Exhaust	a	14 1/2"	3 1/2"	3 1/2"
Air vent	b	7 3/4"	5 3/4"	5 3/4"
Air inlet	c	14 3/4"	6 1/2"	5 3/4"
Relief valve	d	2 1/4"	3 1/4"	2 1/2"

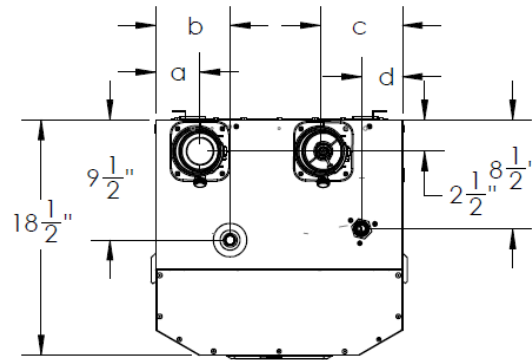

BOTTOM

	DIM	FTV110	FTV150	FTV190
CH out	e	6 1/4"	5 1/2"	6 1/4"
DHW out	f	7 1/2"	6 1/2"	7 1/4"
DHW in	g	7 1/4"	8 1/4"	7 1/2"
CH in	h	6 1/4"	7"	6 1/4"
drain	i	14 1/2"	6 1/4"	2 1/2"

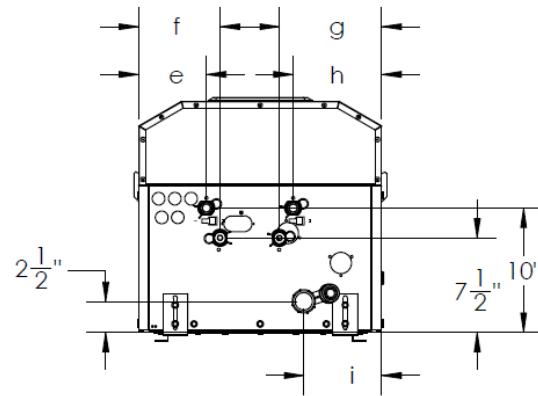

RECOMMENDED CLEARANCES - in. [mm]

Front	Top	Sides	Back	Bottom	Flue Pipe
36 [914]	24 [610]	12 [305]	0	24 [610]	1 [25]



NTI Boilers Inc.

NTI Boilers Inc. 30 Stonegate Drive, Saint John, NB E2H 0A4 Canada
 Technical Services: 1-800-688-2575 Fax: 1-506-432-1135 Web: [http:// www.ntiboilers.com](http://www.ntiboilers.com)
 NTI Boilers Inc. reserves the right to change these specifications without notice



Trinity FTV Combi (110, 150 and 190MBH) High Efficiency Gas-Fired Condensing Boiler

SUBMITTAL SHEET
Section 1 – General Specifications
Section 2 – Product Dimensions
Section 3 – Field Wiring

3 -- FIELD WIRING

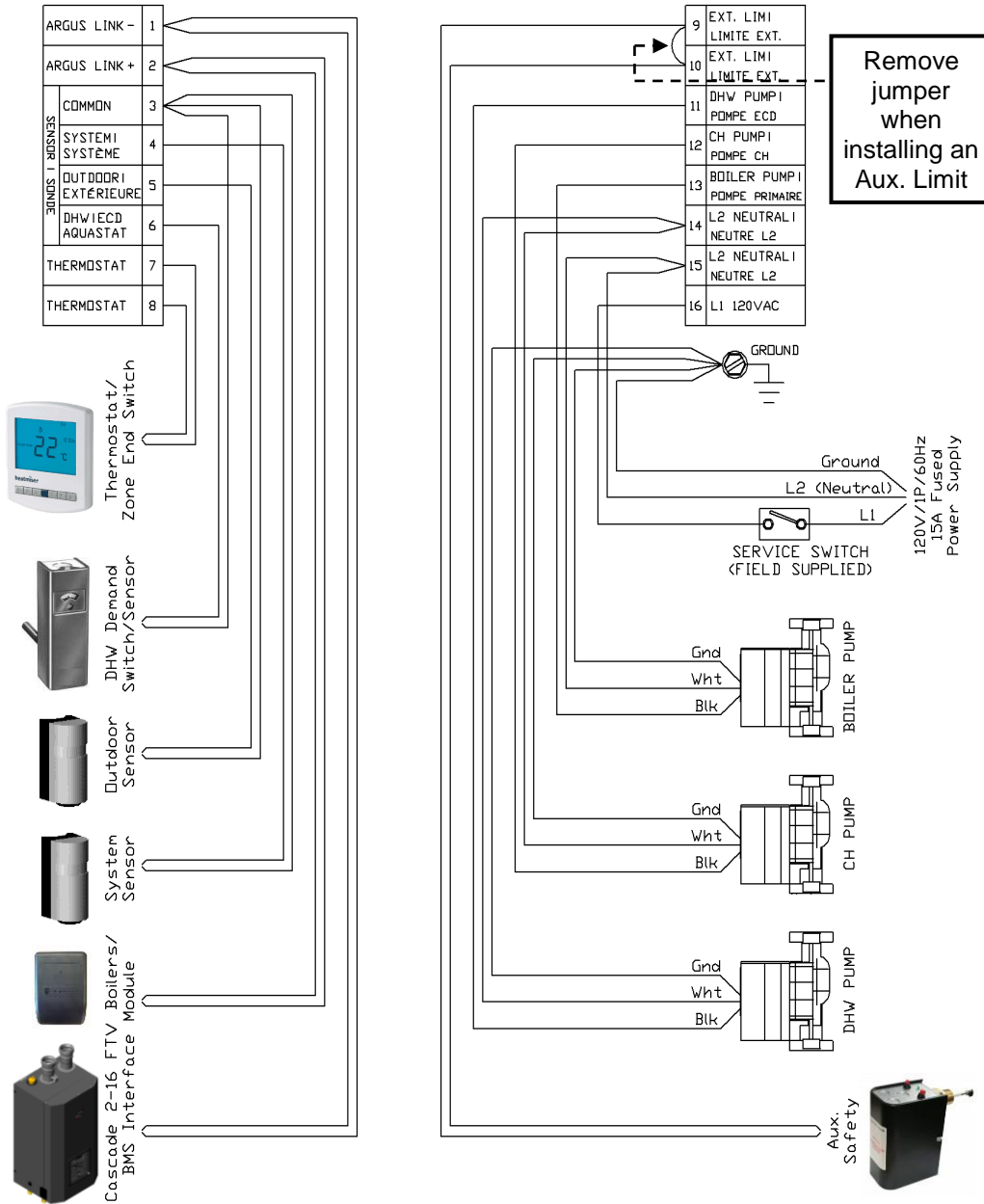

NTI Boilers Inc.

NTI Boilers Inc. 30 Stonegate Drive, Saint John, NB E2H 0A4 Canada
Technical Services: 1-800-688-2575 Fax: 1-506-432-1135 Web: [http:// www.ntiboilers.com](http://www.ntiboilers.com)
NTI Boilers Inc. reserves the right to change these specifications without notice